



TRB245



HARDWARE

FRONT VIEW

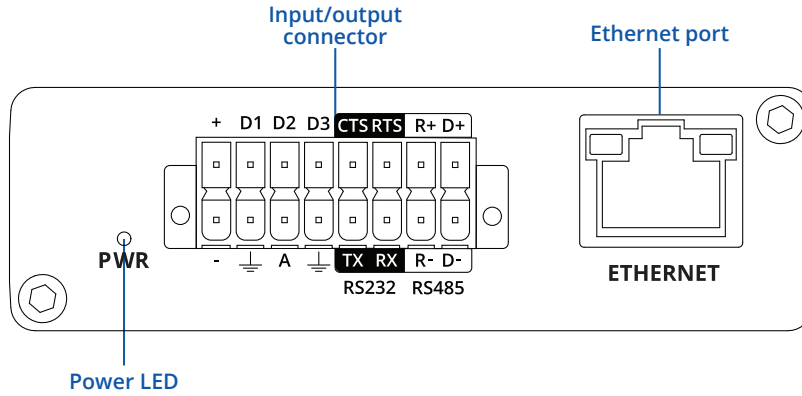

BACK VIEW

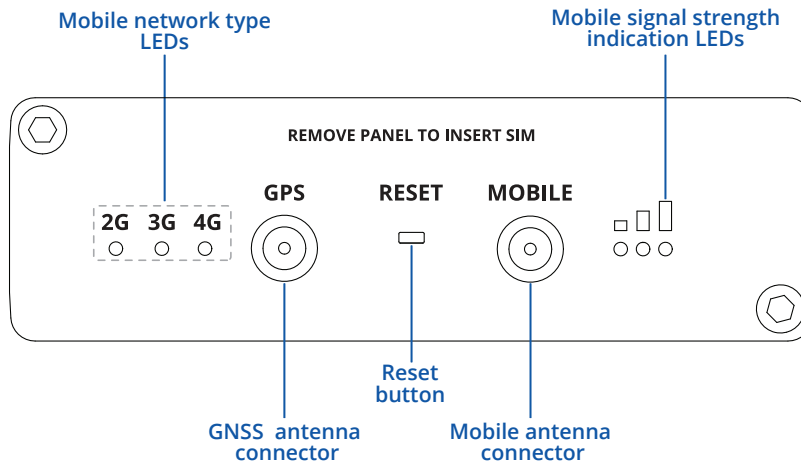

INPUT/OUTPUT 16 PIN CONNECTOR PINOUT

- D1, D2, D3** - Configurable digital Input/Output pins. Open collector output, max output 30 V, 300 mA or Digital input where 0-6 V detected as logic low and 8-30 V – logic high.
- +** - 9-30 VDC positive power pin
- CTS** - RS232 clear data to send pin (output).
- RTS** - RS232 request data to send pin (input).
- R+** - RS485 receiver positive signal pin.
- D+** - RS485 driver positive signal pin.
- - Negative/ground power pin.
- ⊥** - Ground pins for D1, D2, D3, A, RS232 and RS485.
- A** - Analog input pin. Analog voltage range 0-30 V.
- TX** - RS232 transmitted data (input).
- RX** - RS232 received data (output).
- R-** - RS485 receiver negative signal.
- D-** - RS485 driver negative signal.

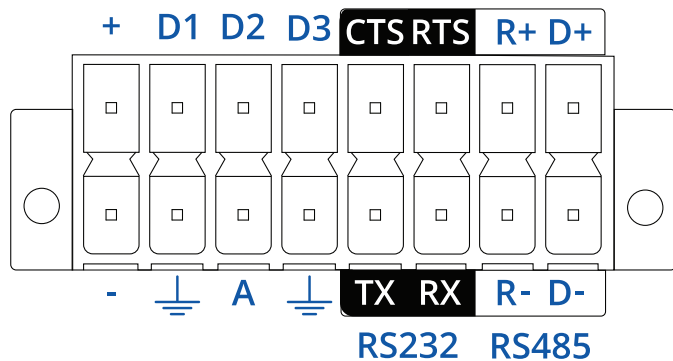

FEATURES

MOBILE

Mobile module	4G (LTE) – Cat 4 up to 150 Mbps, 3G – Up to 42 Mbps, 2G – Up to 236.8 kbps
SIM switch	2 SIM cards, auto-switch cases: weak signal, data limit, SMS limit, on roaming, no network, network denied, data connection fail
Status	Signal strength (RSSI), SINR, RSRP, RSRQ, EC/IO, RSCP Bytes sent/received, connected band, IMSI, ICCID.
SMS/Call	SMS status, SMS configuration, send/read SMS via HTTP POST/GET, EMAIL to SMS, SMS to EMAIL, SMS to HTTP, SMS to SMS, scheduled SMS, SMS autoreply, Call utilities
USSD	Supports sending and reading Unstructured Supplementary Service Data messages
Black/White list	Operator black/white list
Band management	Used band status display, Band lock
APN	Auto APN
Bridge	Direct connection (bridge) between mobile ISP and device on LAN
Multiple PDN	Possibility to use different PDNs for multiple network access and services

ETHERNET

LAN	1 x LAN port 10/100 Mbps, comply IEEE 802.3, IEEE 802.3u standards, supports auto MDI/MDIX crossover (Configurable to work as WAN port)
-----	---

NETWORK

Routing	Static routing, Dynamic routing (BGP, OSPF v2, RIP v1/v2) (planned)
Network protocols	TCP, UDP, IPv4, IPv6, ICMP, NTP, DNS, HTTP, HTTPS, FTP, SMTP, SSL v3, TLS, ARP, PPP, SSH, DHCP, Telnet, MQTT, Wake On Lan (WOL)
VoIP passthrough support (planned)	H.323 and SIP-alg protocol NAT helpers, allowing proper routing of VoIP packets
Connection monitoring	Ping Reboot, Periodic Reboot, LCP and ICMP for link inspection
Firewall	Port forward, traffic rules, custom rules
QoS / Smart Queue Management (SQM) (planned)	Traffic priority queuing by source/destination, service, protocol or port, WMM, 802.11e
DDNS	Supported >25 service providers, others can be configured manually
SSHFS	Possibility to mount remote file system via SSH protocol

SECURITY

Authentication	Pre-shared key, digital certificates, X.509 certificates
Firewall	Pre-configured firewall rules can be enabled via WebUI, unlimited firewall configuration via CLI; DMZ; NAT; NAT-T
Attack prevention	DDOS prevention (SYN flood protection, SSH attack prevention, HTTP/HTTPS attack prevention), port scan prevention (SYN-FIN, SYN-RST, X-mas, NULL flags, FIN scan attacks)
VLAN (planned)	Tag based VLAN separation
Mobile quota control	Custom data limits for both SIM cards
WEB filter (planned)	Blacklist for blocking out unwanted websites, Whitelist for specifying allowed sites only
Access control	Flexible access control of TCP, UDP, ICMP packets, MAC address filter

VPN

OpenVPN	Multiple clients and server can be running simultaneously, 12 encryption methods
OpenVPN Encryption	DES-CBC, RC2-CBC, DES-EDE-CBC, DES-EDE3-CBC, DESX-CBC, BF-CBC, RC2-40-CBC, CAST5-CBC, RC2-64-CBC, AES-128-CBC, AES-192-CBC, AES-256-CBC
IPSec	IKEv1, IKEv2, with 5 encryption methods (DES, 3DES, AES128, AES192, AES256)
GRE	GRE tunnel
Stunnel (planned)	Proxy designed to add TLS encryption functionality to existing clients and servers without any changes in the program's code
PPTP, L2TP	Client/Server services can run simultaneously, L2TPv3 support
DMVPN (planned)	Method of building scalable IPsec VPNs
SSTP (planned)	SSTP client instance support
ZeroTier	ZeroTier VPN client support
WireGuard	WireGuard VPN client and server support

SERIAL COMMUNICATION MODES

Modes	Console, OverIP, Modem (Full or Partial control), MODBUS RTU master, MODBUS gateway, NTRIP client (planned)
-------	---

MODBUS TCP SLAVE

ID filtering	Respond to one ID in range [1;255] or any
Allow remote access	Allow access through WAN
Custom registers	MODBUS TCP custom register block, which allows to read/write to a file inside the router, and can be used to extend MODBUS TCP slave functionality

MODBUS TCP MASTER

Supported functions	01, 02, 03, 04, 05, 06, 15, 16
Supported data formats	8 bit: INT, UINT; 16 bit: INT, UINT (MSB or LSB first); 32 bit: float, INT, UINT (ABCD (big-endian), DCBA (little-endian), CDAB, BADC), HEX, ASCII

MODBUS RTU MASTER

Supported baud rates	From 300 to 3000000
Supported functions	01, 02, 03, 04, 05, 06, 15, 16
Supported data formats	8 bit: INT, UINT; 16 bit: INT, UINT (MSB or LSB first); 32 bit: float, INT, UINT (ABCD (big-endian), DCBA (little-endian), CDAB, BADC), HEX, ASCII
Number of data bits	7 or 8
Number of stop bits	1 or 2
Parity bits	None, Even, Odd

MQTT GATEWAY

Gateway	Allows sending commands and receiving data from MODBUS Master through MQTT broker
---------	---

DATA TO SERVER

Protocols	HTTP(S), MQTT, Azure MQTT, Kinesis
-----------	------------------------------------

MONITORING & MANAGEMENT

WEB UI	HTTP/HTTPS, status, configuration, FW update, CLI, troubleshoot, event log, system log, kernel log
FOTA	Firmware update from server, automatic notification
SSH	SSH (v1, v2)
SMS	SMS status, SMS configuration, send/read SMS via HTTP POST/GET
Call	Reboot, Status, Mobile data on/off, Output on/off, answer/hang-up with a timer
TR-069	OpenACS, EasyCwmp, ACSLite, tGem, LibreACS, GenieACS, FreeACS, LibCWMP, Friendly tech, AVSystem
MQTT	MQTT Broker, MQTT publisher
SNMP	SNMP (v1, v2, v3), SNMP Trap
JSON-RPC	Management API over HTTP/HTTPS
MODBUS	MODBUS TCP status/control
RMS	Teltonika Remote Management Systems (RMS)

IoT PLATFORMS

Cloud of Things	Allows monitoring of: Device data, Mobile data, Network info, Availability
ThingWorx	Allows monitoring of: WAN Type, WAN IP Mobile Operator Name, Mobile Signal Strength, Mobile Network Type
Cumulocity	Allows monitoring of: Device Model, Revision and Serial Number, Mobile Cell ID, ICCID, IMEI, Connection Type, Operator, Signal Strength, WAN Type and IP
Azure IoT Hub	Can send device IP, Number of bytes send/received/ 3G connection state, Network link state, IMEI, ICCID, Model, Manufacturer, Serial, Revision, IMSI, Sim State, PIN state, GSM signal, WCDMA RSCP, WCDMA EC/IO, LTE RSRP, LTE SINR, LTE RSRQ, CELL ID, Operator, Operator number, Connection type, Temperature, PIN count to Azure IoT Hub server

SYSTEM CHARACTERISTICS

CPU	Qualcomm QCA9531, MIPS 24kc, 650 MHz
RAM	64 MB, DDR2
Flash storage	16MB SPI Flash (4 MB available for user)

FIRMWARE / CONFIGURATION

WEB UI	Update FW from file, check FW on server, configuration profiles, configuration backup
FOTA	Update FW/configuration from server
RMS	Update FW/configuration for multiple devices
Keep settings	Update FW without losing current configuration

FIRMWARE CUSTOMIZATION

Operating system	RutOS (OpenWrt based Linux OS)
Supported languages	Busybox shell, Lua, C, C++
Development tools	SDK package with build environment provided

LOCATION TRACKING

GNSS	GPS, GLONASS, BeiDou, Galileo and QZSS
Coordinates	GNSS coordinates via WebUI, SMS, TAVL, RMS
NMEA	NMEA 0183
NTRIP (planned)	NTRIP protocol (Networked Transport of RTCM via Internet Protocol)
Server software	Supported server software TAVL, RMS
Geofencing	Configurable multiple geofence zones

INPUT/OUTPUT

Configurable I/O	3 x Configurable Inputs/Outputs. Digital input 0 - 6 V detected as logic low, 8 - 30 V detected as logic high. Open collector output, max output 30 V, 300 mA
Analog input	1 x Analog input (0 - 30 V)
Output control	HTTP POST/GET, Schedule
Events	SMS, Email
I/O juggler	Allows to set certain I/O conditions to initiate event

SERIAL

RS232	Terminal block connector: TX, RX, RTS, CTS
RS485	Terminal block connector: D+, D-, R+, R- (2 or 4 wire interface)
Supported baud rates	From 300 to 3000000
Number of data bits	7 or 8
Number of stop bits	1 or 2
Parity	None, Even, Odd
Flow control	None, RTS/CTS (only for RS232 interface), Xon/Xoff

POWER

Connector	2 pins in 16 pin industrial terminal block
Input voltage range	9 – 30 VDC, reverse polarity protection, surge protection +/-1 kV 50 µs max
Power consumption	Idle: <1.2 W, Max: <5 W

PHYSICAL SPECIFICATION

Casing material	Aluminium housing with DIN rail mounting option
Dimensions (W x H x D)	83 x 25 x 74.2 mm
Weight	165 g
Mounting options	DIN rail, wall mounting (additional kits needed), flat surface placement

PHYSICAL INTERFACES (PORTS, LEDS, ANTENNAS, BUTTON, SIM)

Ethernet	1 x RJ45 port, 10/100 Mbps
I/O's	3 x Configurable I/O, 1 x Analog input in 16 pin terminal block
Status LEDs	3 x connection status LEDs, 3 x connection strength LEDs, 1 x power LED, 1 x Eth port status LED
SIM	2 x SIM slots (Mini SIM - 2FF), 1.8 V/3 V, double stacked SIM tray
Power	2 pins in 16 pin terminal block
Antennas	1 x SMA connector for LTE, 1 x SMA connector for GNSS
RS232	4 pins in 16 pin terminal block (TX, RX, RTS, CTS)
RS485	4 pins in 16 pin terminal block (D+, D-, R+, R-)
Reset	Reboot/User default reset/Factory reset button

OPERATING ENVIRONMENT

Operating temperature	-40 C to 75 C
Operating humidity	10% to 90% non-condensing

HARDWARE INSTALLATION

1. Unscrew two back panel hex bolts and remove the back panel.
2. Insert your SIM card(s) into the SIM socket(s), which are located on the bottom side of PCB.
3. Attach the panel and tighten the hex bolts.
4. Attach the mobile antenna (max torque 0.4 N·m / 3.5 lbf·in).

5. Connect open PSU leads to 16 pin terminal block:
 - a) red wire to top row first contact (+);
 - b) black wire to bottom row first contact (-).
6. Connect the 16 pin terminal block to gateway 16 pin connector and plug other end of the power adapter into a power outlet.

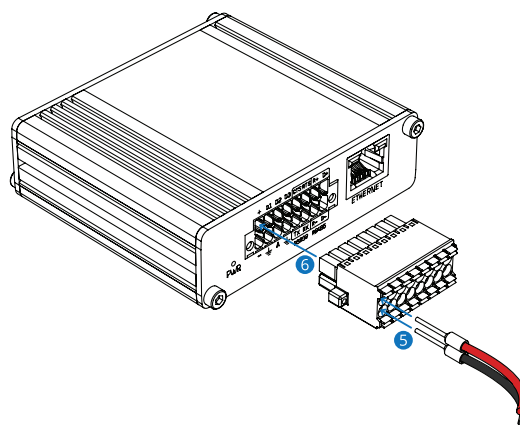
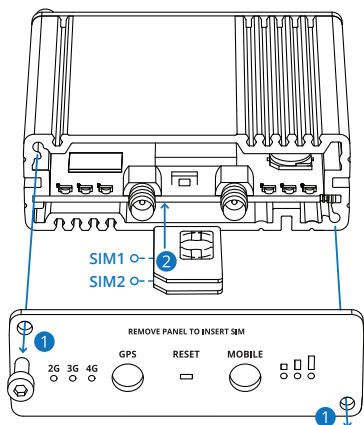

LOGIN TO DEVICE

1. Power on the device and connect the Ethernet cable to your computer.
2. Allow the gateway to boot up. This might take up t
3. To enter the gateway Web interface (WebUI), type <http://192.168.1.1> into the URL field of your Internet browser.
4. Use login information shown in image A when prompted for authentication.
5. After you log in, you will be prompted to change your password for security reasons. The new password must contain at least 8 characters, including at least one uppercase letter, one lowercase letter and one digit. This step is mandatory, and you will not be able to interact with the gateway WebUI until you change the password.
6. When you change the gateway password, the Configuration Wizard will start. The Configuration Wizard is a tool used to set up some of the gateway main operating parameters.
7. Go to the Overview page and pay attention to the Signal Strength indication (image B). To maximize the cellular performance try adjusting the antennas or changing the location of your device to achieve the best signal conditions.

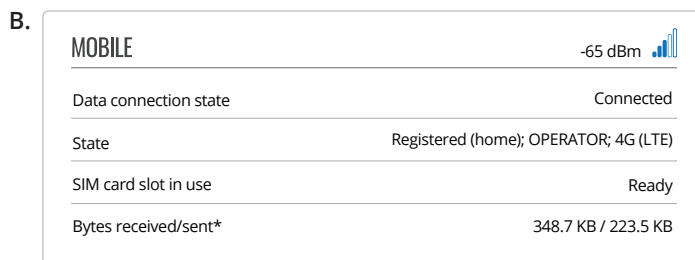
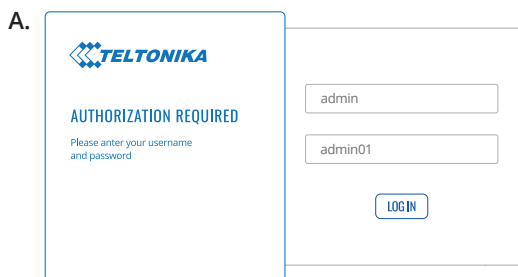

TECHNICAL INFORMATION

Radio specifications	
RF technologies	2G, 3G, 4G, GNSS
Max RF power	33 dBm@GSM, 24 dBm@WCDMA, 23 dBm@LTE
Bundled accessories specifications*	
Power adapter	Input: 0.4 A@100-240 VAC, output: 9 VDC, 1 A, connected to 16 pin terminal block
Mobile antenna	698~960 / 1710~2690 MHz, 50 Ω, VSWR < 3, gain** 3 dBi, omnidirectional, SMA male connector
GNSS antenna	1575.42~1602 MHz, 2.2~5 VDC, VSWR < 1.5, gain** 28 dB (typ.), RHCP polarization, SMA male connector

*Order code dependent.



**Higher gain antenna can be connected to compensate for cable attenuation when a cable is used. The user is responsible for the compliance with the legal regulations.

WHAT'S IN THE BOX?

STANDARD PACKAGE CONTAINS*

- TRB245
- 9 W PSU
- 1 x LTE antenna (swivel, SMA male)
- 1x GNSS antenna (adhesive, SMA male, 3 m cable)
- 16 pin terminal block
- 1 x hex key
- Ethernet cable (1.5 m)
- QSG (Quick Start Guide)
- RMS Flyer
- Packaging box



 <p>TRB245</p>	 <p>9 W PSU</p>	 <p>1 X LTE ANTENNA (SWIVEL, SMA MALE)</p>
 <p>1X GNSS ANTENNA (ADHESIVE, SMA MALE, 3 M CABLE)</p>	 <p>16 PIN TERMINAL BLOCK</p>	 <p>1 X HEX KEY</p>
 <p>ETHERNET CABLE (1.5 M)</p>		

* For all standard order codes standard package contents are the same, except for PSU.

STANDARD ORDER CODES

PRODUCT CODE	HS CODE	HTS CODE	PACKAGE CONTAINS
TRB245 000000	851762	8517.62.00	Standard Package with Euro PSU
TRB245 100100	851762	8517.62.00	Standard Package with US PSU

For more information on all available packaging options – please contact us directly.

AVAILABLE VERSIONS

PRODUCT CODE	REGION (OPERATOR)	FREQUENCY
TRB245 0*****	Europe, the Middle East, Africa, Thailand	<ul style="list-style-type: none"> ● 4G (LTE-FDD): B1, B3, B7, B8, B20, B28A ● 4G (LTE-TDD): B38, B40, B41 ● 3G: B1, B8 ● 2G: B3, B8
TRB245 1*****	North America	<ul style="list-style-type: none"> ● 4G (LTE-FDD): B2, B4, B5, B12, B13, B14, B66, B71 ● 3G: B2, B4, B5
TRB245 2*****	Latin America, Australia, New Zealand	<ul style="list-style-type: none"> ● 4G (LTE-FDD): B1, B2¹, B3, B4, B5, B7, B8, B28 ● 4G (LTE-TDD): B40 ● 3G: B1, B2, B5, B8 ● 2G: B2, B3, B5, B8
TRB245 3*****	China	<ul style="list-style-type: none"> ● 4G (LTE-FDD): B1, B3 ● 4G (LTE-TDD): B38, B39, B40, B41 ● 3G (TDSCDMA): B34, B39 ● 3G (WCDMA): B1 ● 3G (CDMA 1x/EVDO): BC0 ● 2G: B3, B8

The price and lead-times for region (operator) specific versions may vary. For more information please contact us.
 1 - LTE-FDD B2 does not support Rx-diversity.

MOUNTING OPTIONS

DIN RAIL KIT

Parameter	Value
Mounting standard	35mm DIN Rail
Material	Low carbon steel
Weight	57g
Screws included	Philips Pan Head screw #6-32×3/16, 2pcs
Dimensions	82 mm x 46 mm x 20 mm
RoHS Compliant	V

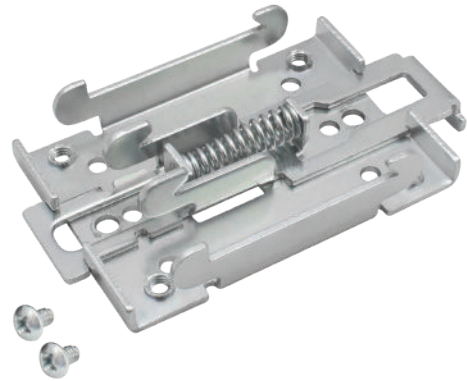

DIN RAIL KIT

- DIN Rail adapter
- Philips Pan Head screw #6-32×3/16, 2pcs for RUT2xx/RUT9xx

ORDER CODE

PR5MEC00

HS CODE

73269098

HTS CODE

7326.90.98

For more information on all available packaging options – please contact us directly.

COMPACT DIN RAIL KIT

Parameter	Value
Mounting standard	35mm DIN Rail
Material	ABS + PC plastic
Weight	6.5 g
Screws included	Philips Pan Head screw #6-32×3/16, 2pcs
Dimensions	70 mm x 25 mm x 14,5 mm
RoHS Compliant	V



DIN RAIL KIT

- Compact plastic DIN Rail adapter (70x25x14,5mm)
- Philips Pan Head screw #6-32×3/16, 2pcs

ORDER CODE

PR5MEC11

HS CODE

73269098

HTS CODE

7326.90.98

For more information on all available packaging options – please contact us directly.

SURFACE MOUNTING KIT

Parameter	Value
Mounting standard	Flat surface mount
Material	ABS + PC plastic
Weight	2x5 g
Screws included	Philips Pan Head screw #6-32×3/16, 2pcs
Dimensions	25 mm x 48 mm x 7.5 mm
RoHS Compliant	V



DIN RAIL KIT

- Surface mounting kit
- Philips Pan Head screw #6-32×3/16, 2pcs

ORDER CODE

PR5MEC12

HS CODE

73269098

HTS CODE

7326.90.98

For more information on all available packaging options – please contact us directly.

TRB245 SPATIAL MEASUREMENTS & WEIGHT

MAIN MEASUREMENTS

W x H x D dimensions for TRB245:

Device housing*:	83 x 25 x 74.2
Box:	173 x 71 x 148

*Housing measurements are presented without antenna connectors and screws; for measurements of other device elements look to the sections below.

TOP VIEW

The figure below depicts the measurements of TRB245 and its components as seen from the top:

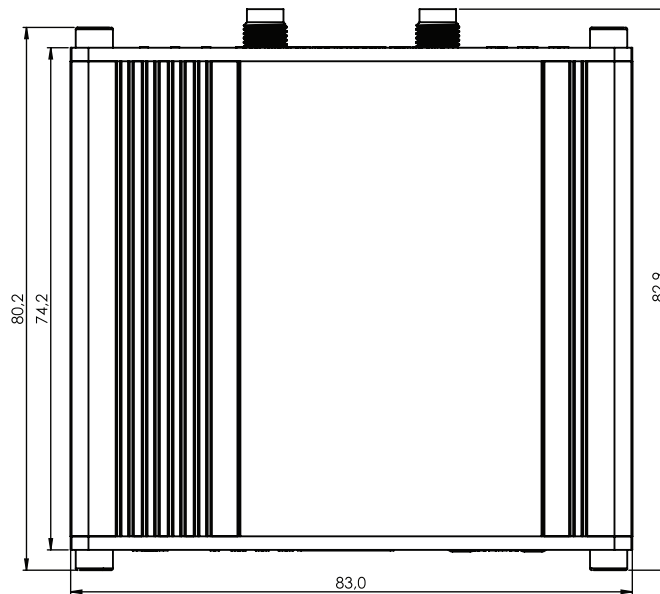

RIGHT VIEW

The figure below depicts the measurements of TRB245 and its components as seen from the right side:

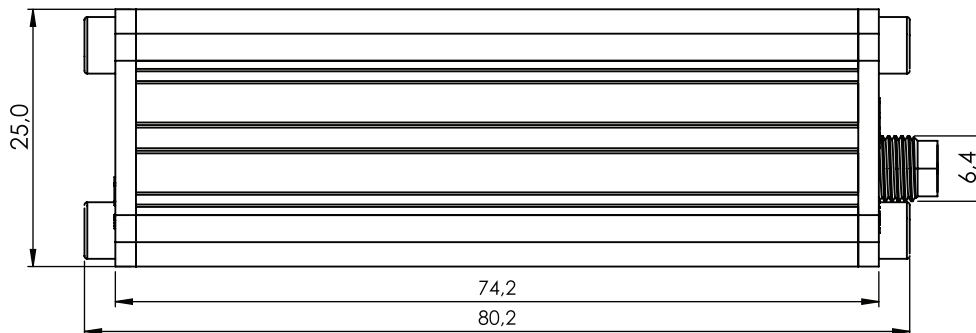

FRONT VIEW

The figure below depicts the measurements of TRB245 and its components as seen from the front panel side:

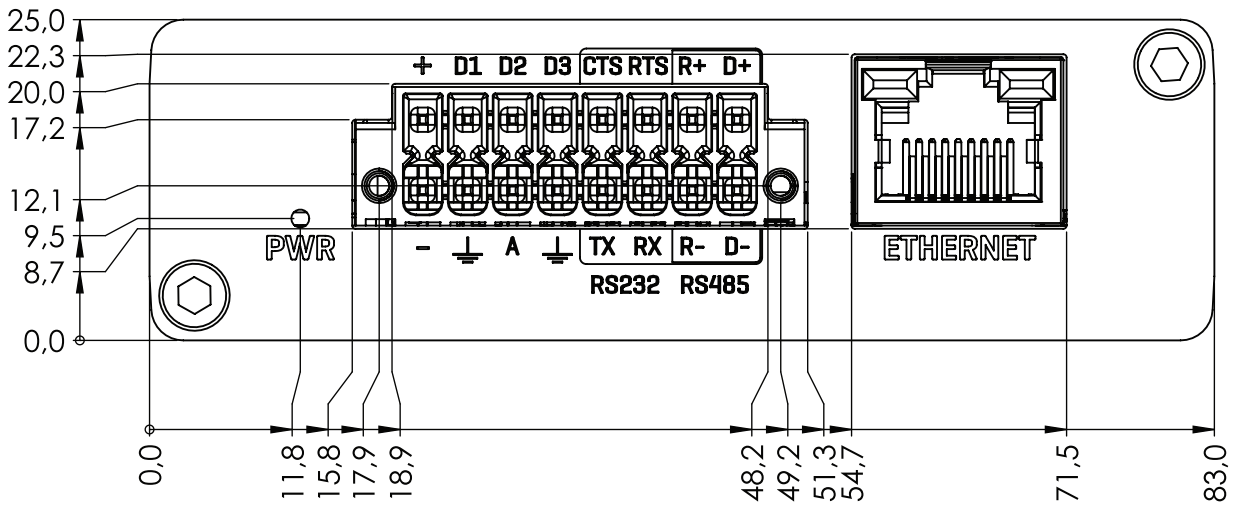

REAR VIEW

The figure below depicts the measurements of TRB245 and its components as seen from the back panel side:

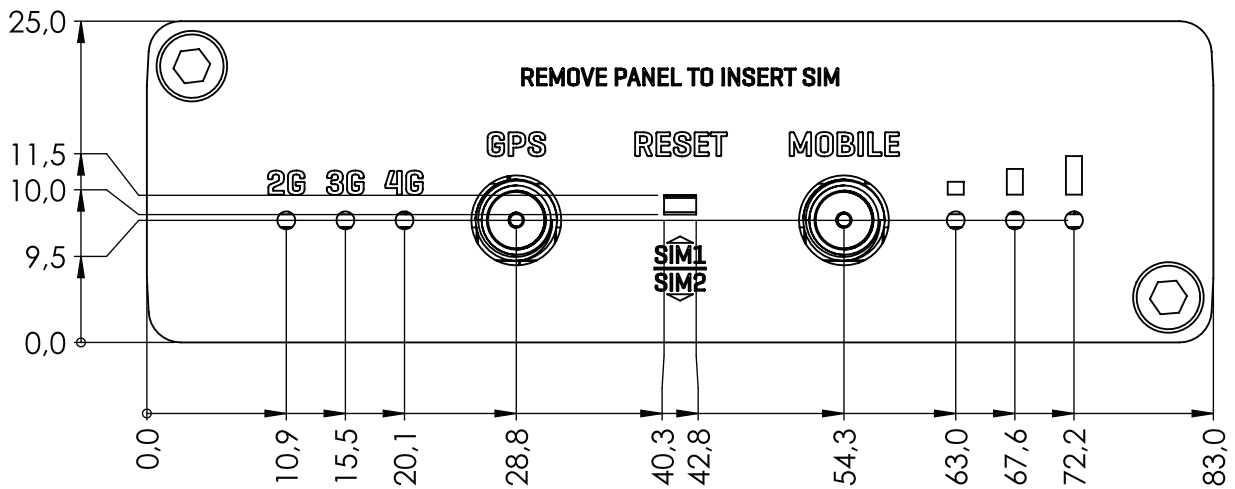

MOUNTING SPACE REQUIREMENTS

The figure below depicts an approximation of the device's dimensions when cables and antennas are attached:

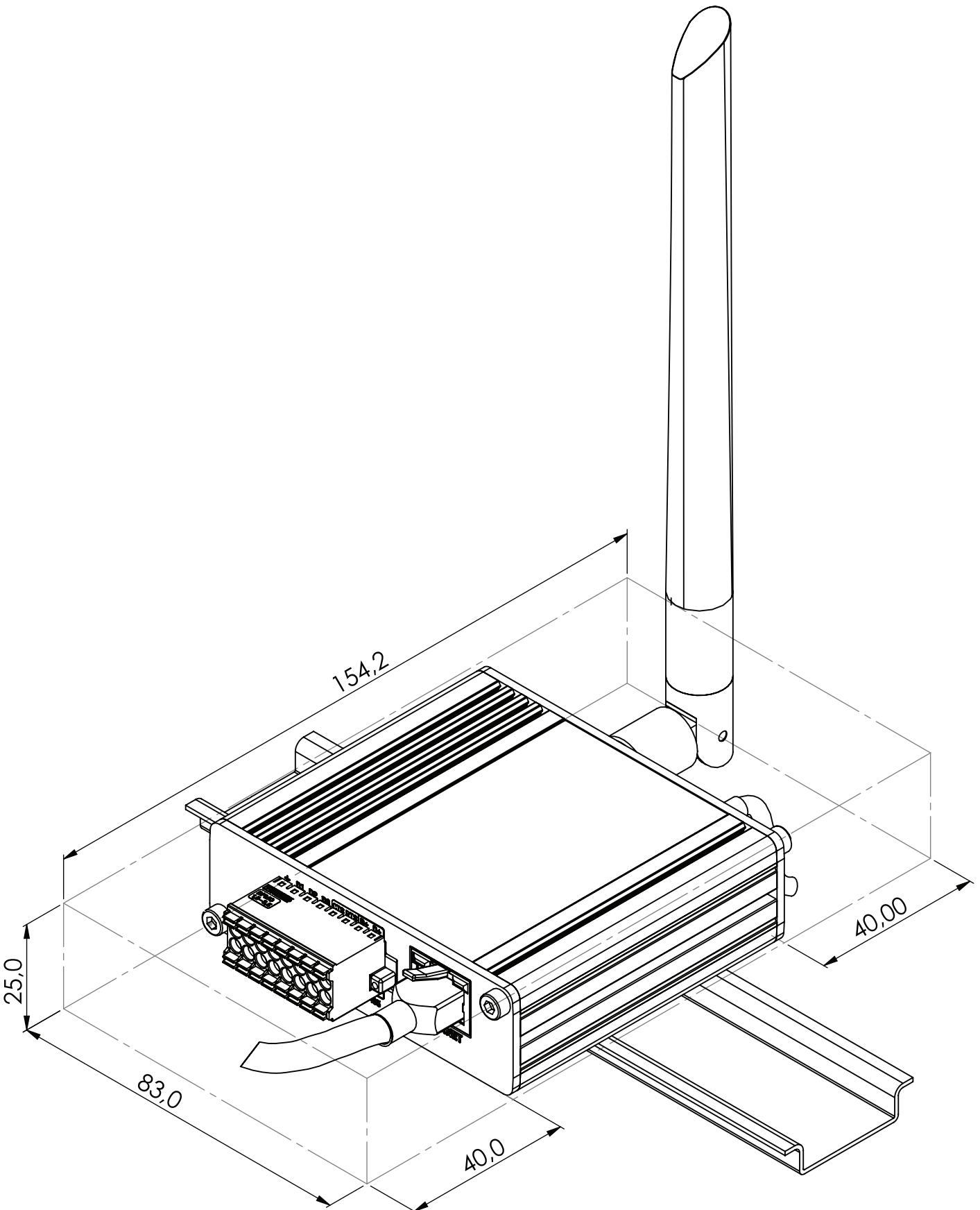

DIN RAIL

The scheme below depicts protrusion measurements of an attached DIN Rail:

