

AV Cart 75

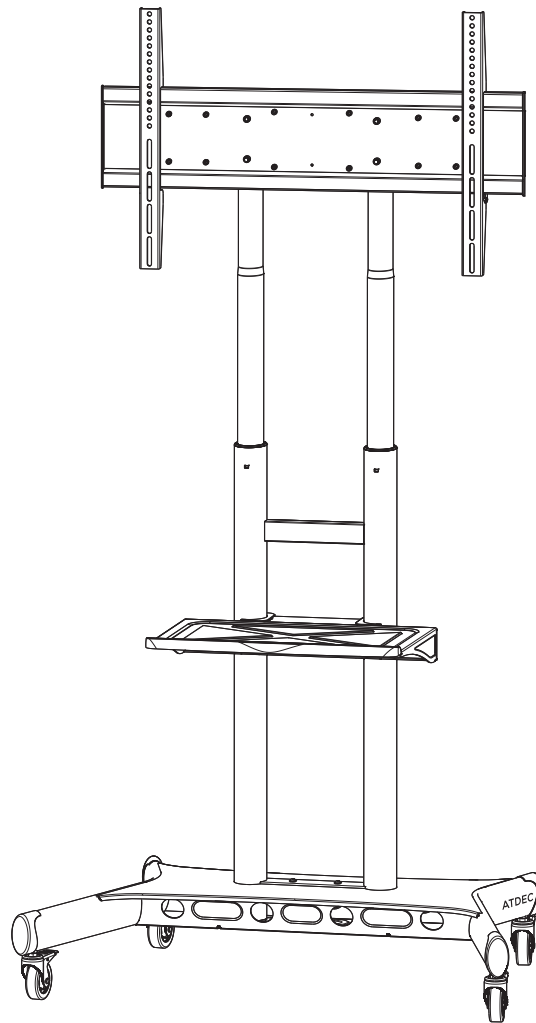

FEATURES

- Robust cart to hold larger displays and equipment
- Telescopic height adjustment
- Height adjustable equipment shelf
- Concealed cable management through column or use supplied hook and loop to secure cables to outside of column
- Spring button for convenient height adjustment (display must be removed prior to height adjustment)
- ø75mm (3") lockable castors

Display weight	0 - 75kg (0 - 165lb)*
Display size	50" - 80"
Shelf capacity	0 - 11kg (0 - 24lb)
Height adjustment	300mm (11.8")
Shelf adjustment	620mm (24.4")
VESA mounting	200x200 - 800x500
Primary material	Steel

*Curved monitors, deep devices (such as all-in-one PCs), VESA mounted accessories (such as mini PC brackets and mounts), and offset VESA locations exert additional leverage that can exceed the capacity of the mount even though the monitor weight may be within the stated range. Please contact Atdec if you would like further information.

WARRANTY

10 years limited

DIMENSIONS

