

Quick Guide

1. Before Installing

Congratulations on purchasing your **AudioCodes 450HD** or **C450HD IP Phone**!

Before installing your phone, make sure the following items are included in the shipped box:

- ✓ 450HD or C450HD IP Phone
- ✓ AC power adapter (optional)
- ✓ Cat 5e Ethernet cable
- ✓ Handset
- ✓ Handset cord
- ✓ Desktop stand
- ✓ Wall mount

2. Physical Description



3. Cabling the Phone



Warning: Prior to connecting power, refer to the *Compliance and Regulatory Information* document at <https://www.audiocodes.com/library/technical-documents>.

To cable the phone:

1. [Refer to the illustration below] Connect the **short, straight end** of the phone cord to the handset and the **longer straight end** of the cord to the handset jack on the phone.
2. (Optional) Connect a headset to the **RJ-9 headset port**, or to one of the two **USB ports**.
3. Connect the **RJ-45 LAN port** to your LAN network (LAN port or LAN switch/router) with a CAT 5 / 5e Ethernet cable.
4. Connect the **RJ-45 PC port** to a computer with a CAT 5 / 5e straight-through Ethernet cable.
5. Connect the connector tip of the AC power adapter to the phone's **DC 12V power socket** and connect the two-prong AC adapter directly to the electrical wall outlet. When the phone powers up, all the LEDs momentarily light up.

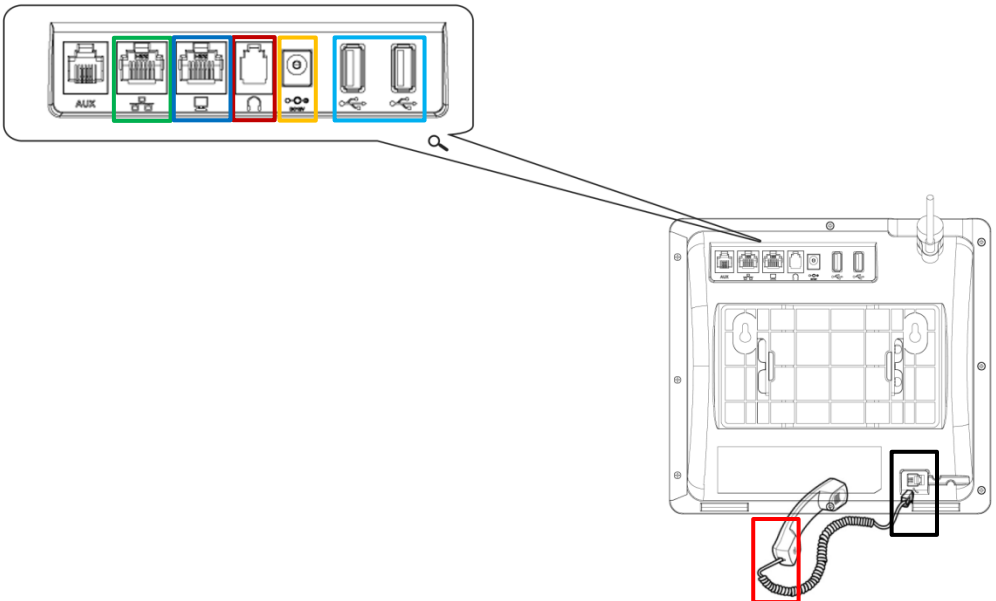

4. Mounting the Phone on a Desktop or Wall

- ✓ **Desktop:** Slide the L-shaped stand's short or long edge **slots** onto **these** rails.
- ✓ **Wall:** Slide the **wall mount fitting** onto **these** rails.

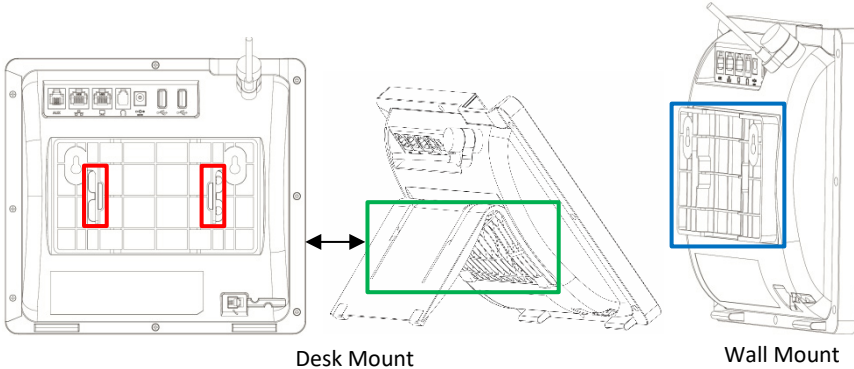

5. Signing In



Note: This section is applicable only to Skype for Business/Teams Compatible.

- ☞ **To sign in with Skype for Business client when using BToE:**
Refer to the [450HD](#) or the [C450HD](#) IP Phone User's Manual.
- ☞ **To sign in with a PIN code (excludes access to Microsoft Outlook Calendar):**
 1. In the Offline idle screen, touch **Sign In**, and then touch the PIN Code option.
 2. Enter the phone number and PIN, and then touch **Select**.

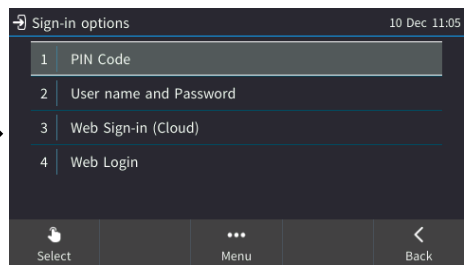
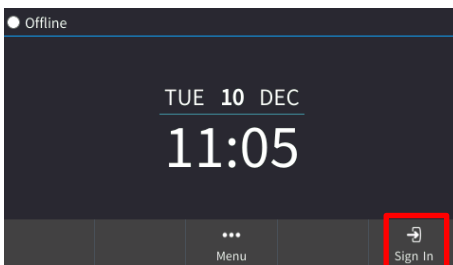

☛ **To sign in with a username and password:**

1. In the Offline idle screen, touch **Sign In**, and then touch the **User name and Password** option.

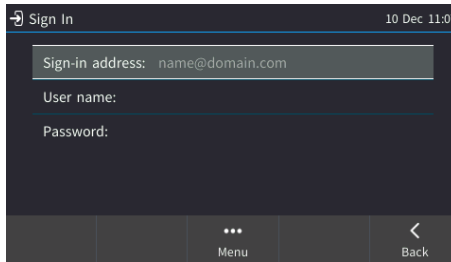

2. Enter the 'Sign-in address' (SIP address), (e.g., john.doe@enterprise.com) and 'User name', (e.g., johnd@enterprise.com), and then enter the password. Get it from the network administrator (it's the same as the Windows credentials).
3. Touch the **Select** softkey.

☛ **To sign in with Web Sign-in (Cloud) (applies only to Microsoft Cloud PBX users):**

1. In the Offline idle screen, touch **Sign In**, and then select the **Web Sign-in (Cloud)** option.

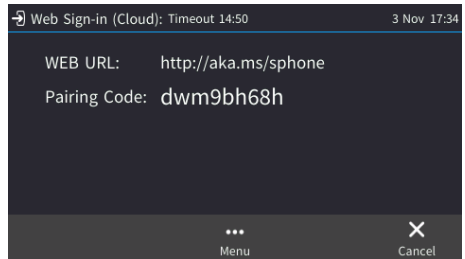
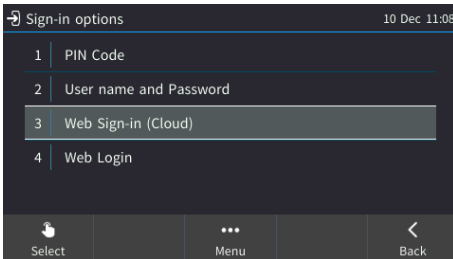

2. Using your web browser, navigate to the URL (Microsoft's Cloud PBX login page) shown in the Web Sign-in (Cloud) screen (above).
3. Enter the pairing code, and then click **Next**:



Enter code

Enter the code displayed on your app or device.

Code

Next

4. Enter the 'Sign-in address' (SIP address), (e.g., john.doe@enterprise.com) and 'User name', (e.g., johnd@enterprise.com), and then enter the password.

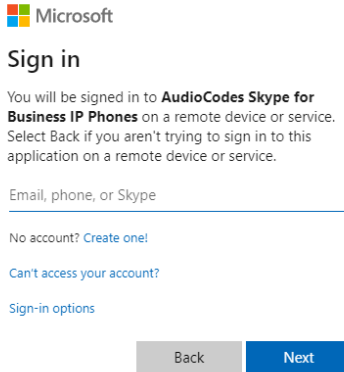

To sign in with Web Login:

1. In the Offline idle screen, touch **Sign In**, and then touch the **Web Login** option.

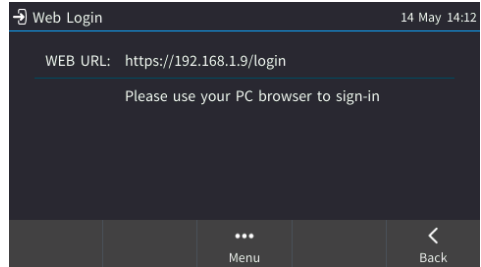
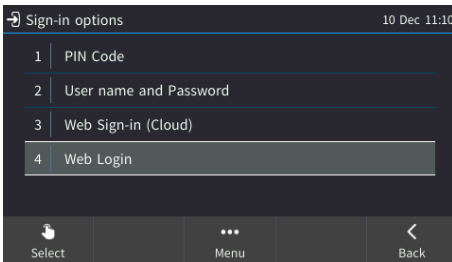

2. Using your web browser, navigate to the URL shown in the Web Login screen (above).
3. Enter the 'Sign-in address' (SIP address), 'User name' and 'Password', and then click **Sign in**.

Web Login	
Sign-in address	<input type="text" value="jname@domain.com"/>
User name	<input type="text" value="name@domain"/>
Password	<input type="password" value="*****"/>
	<input type="button" value="Sign in"/>

☛ **To sign in with the Device Manager:**

If the IP phone is managed by the Device Manager, web login is performed using a dedicated web login screen.

1. Using your web browser, navigate to the URL shown in the Web Login screen (below).
2. Enter the 'Code ID', 'Sign-in address' (SIP address) and 'User Name', and then enter the 'Password'.

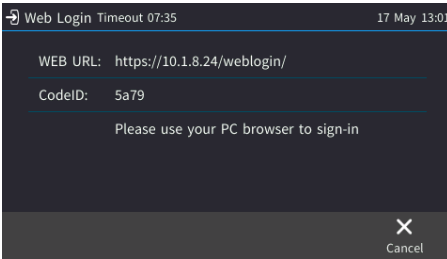

☛ **To sign out:** Touch the **STATUS** menu when the phone is idle, and then touch **SIGN OUT**.



Note: Some Skype for Business/Teams Compatible features are supported only when signing in with username and password (e.g., Calendar).

6. Changing your Presence Status



Note: This section is applicable only to Skype for Business/Teams Compatible.

- ☞ **To change your presence:** Touch the **STATUS** menu, touch the required presence option, and then touch the **SELECT** menu.
- ☞ **To enable Skype for Business to automatically update presence:** Touch the **STATUS** menu, and then navigate to and select **Reset**.

Presence →



7. Basic Phone Operations

- ☞ **To make a call:** Enter a phone number, and then touch the **DIAL** menu. To call a phone contact, touch the **DIRECTORY** menu, select the directory contact, and then touch the **DIAL** menu.
- ☞ **To redial a number:** Press the **REDIAL** key, select a dialed number, and then touch the **DIAL** menu.
- ☞ **To answer a call:** Pick up the handset, or press the speaker or headset key.
- ☞ **To put a call on hold and make another call:** Press the **HOLD** key on the phone, touch the **CALL MENU** and then select **New Call**. Enter a phone number, and then press **DIAL**. To return to the held call, navigate to the held call, and then uncheck the **HOLD** touch menu.
- ☞ **To mute yourself:** Press the mute key. To unmute yourself, press the mute key again.
- ☞ **To transfer a call:** During a call, press the **TRANSFER** key on the phone, enter a number in the **Transfer to...** field, and then press the **TRANSFER** touch menu.
- ☞ **To forward incoming calls to another phone:**
 1. When the phone is idle, touch the **FORWARD** menu, and then touch **Forward to a number**.
 2. Enter the number to which you want to forward the calls, and then touch the **START** menu. To deactivate call forwarding, touch the **FORWARD** menu, and then select **Do not forward calls**.

8. Connecting to a Router via Wi-Fi



Note: This section is applicable only to C450HD (models ordered with Wi-Fi functionality).

The phone can connect to an Access Point via Wi-Fi. The Wi-Fi interface can be used to make VoIP calls over Wi-Fi, when the phone is installed in an environment free of LAN/cables. If an Ethernet cable does not connect the phone to a LAN port, the phone displays a "LAN Link Failure" message and a **Networks** softkey.

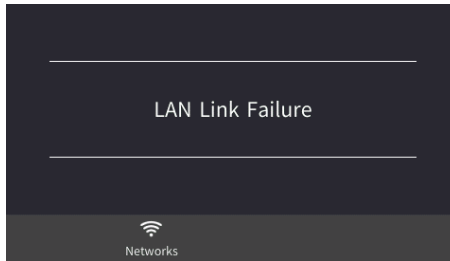

You can connect to Wi-Fi by:

- ✓ Touching the **Networks** softkey in the phone's main menu -or-
- ✓ Navigating to the 'Settings' menu, and then selecting the **Wi-Fi** option.

9. Enabling or Disabling Wi-Fi



Note: This section is applicable only to C450HD (models ordered with Wi-Fi functionality).

To enable Wi-Fi:

1. Using the left and right rim of the navigation button on the phone, select **Enabled** (Wi-Fi is disabled by default):

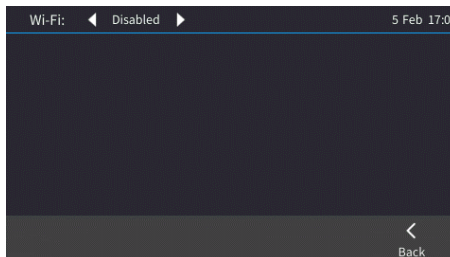

2. After enabling Wi-Fi, "Searching for networks..." is displayed. The phone then displays the available Wi-Fi Access Points. Touch the **Refresh** softkey to display more networks. Select the desired Wi-Fi Access Point (network):

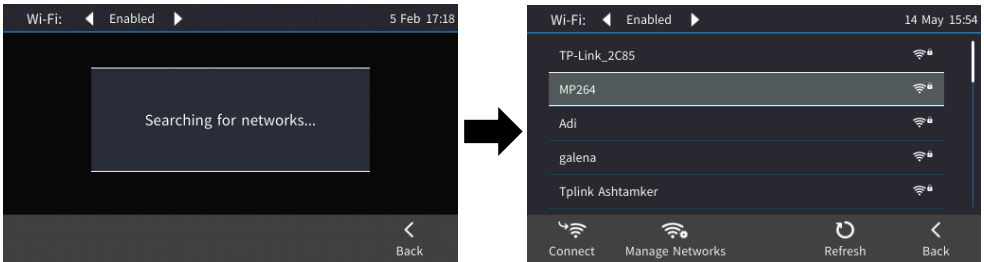

3. Enter the Wi-Fi password if needed, and then touch the **Connect** softkey:

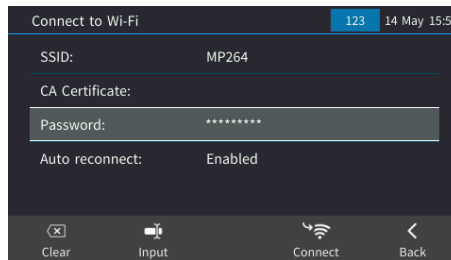

4. When connected to the Access Point, "Connected" is displayed:

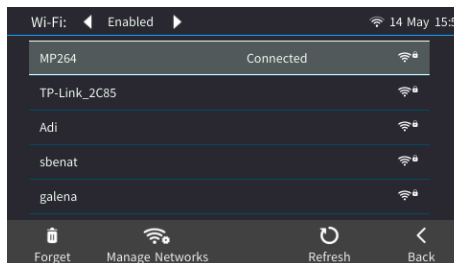

10. Configuring Bluetooth



Note: This section is applicable only to C450HD (models ordered with Bluetooth functionality).

The Bluetooth interface is used to connect the phone to a wireless headset or speaker.

To pair and connect a remote Bluetooth device:

1. Press the phone's **MENU** hard key, and then select the **Settings** option.

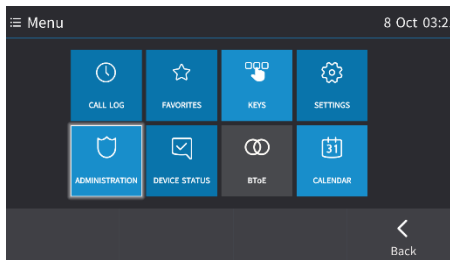

2. In the Settings screen, select the **Bluetooth Settings** option, and then in the Bluetooth Settings screen, select the **Bluetooth Scan** option.

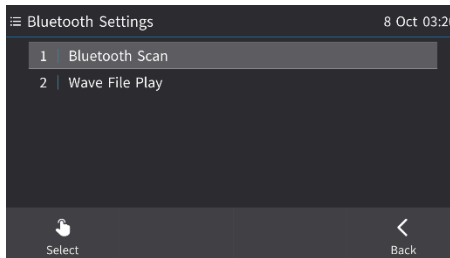

3. The phone starts scanning for Bluetooth devices if there are devices that are not paired:

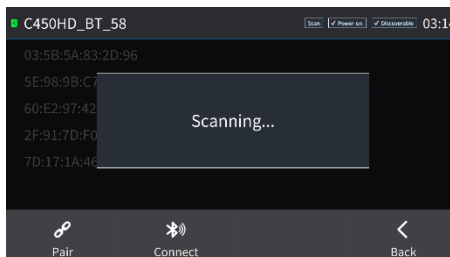

- When the scan finishes, the "Scan finished!!" message is displayed.
- Select one of the Bluetooth devices listed, let it enter 'pair mode', and then click the **Pair** softkey.

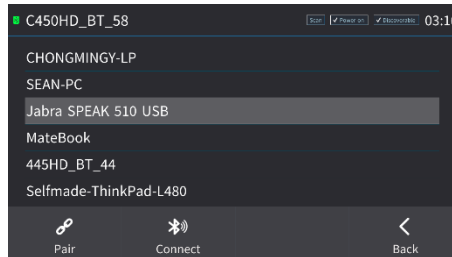

- Once paired successfully, touch the **Connect** softkey to connect the remote device; "Connected" is displayed alongside the device:

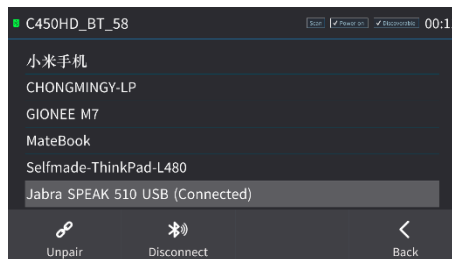

Note: The system does not start scanning automatically if there are paired devices in the list; to scan 'manually', touch the **Scan** key in the top-right corner of the screen.

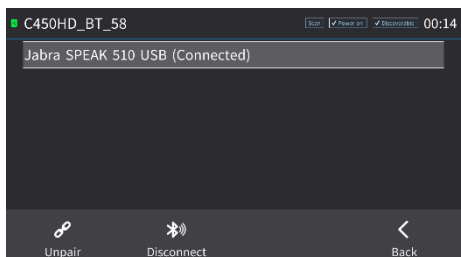
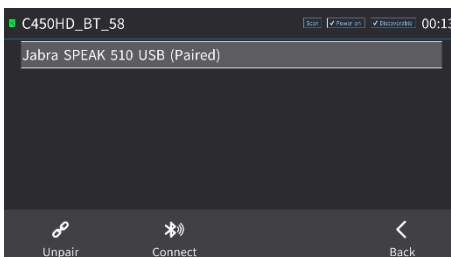

Notice Information

Information contained in this document is believed to be accurate and reliable at the time of printing. However, due to ongoing product improvements and revisions, AudioCodes cannot guarantee accuracy of printed material after the Date Published nor can it accept responsibility for errors or omissions. Updates to this document can be downloaded from <https://www.audiocodes.com/library/technical-documents>.

This document is subject to change without notice.

Date Published: May-26-2020

Document #: LTRT-13248

